



Important notes

All images and technical data in these documents are not finally confirmed and are subject to the final type approval of our vehicles. We will inform you as soon as the final data are available.

All texts, pictures and other information in these dealer documents are subject to the copyright of E-MOBILITY VIETNAM. Any duplication, reproduction or other use without the prior written consent of E-MOBILITY VIETNAM is prohibited.

E-MOBILITY VIETNAM and MANTIS e-Bike are registered trademarks of LEON LEGION. The design of our vehicles is subject to design protection (design protection).

e-Mobility Vietnam

269 Lien Phuong Street, Phuoc Long B Ward

Thu Duc City, Ho Chi Minh City

Vietnam

www.e-mobilityvn.com

Valid from: 03/2022

©Leon Leion, 2022



The technical data is provisional and subject to final type approval of the vehicle. All values are subject to change. We will inform you as soon as new data is available. However, the data mentioned below already give you a first indication and help you in initial discussions with customers. Please point out to customers that these are provisional data.



MANTIS eZERO



MZ001



MZ002

MANTIS eZERO

Motor **E-MOBILITY Rear Hub Motor**
Nominal/Boost Power **250W**
Maximum speed **25 Km/h**
Display **Smart LCD colour**
Battery Type **Lithium-Ion LG 21700 5000mAh**
Battery Specs **36V 10Ah**
Range **50km (Full Power) - 90km (Eco)**
Charge Time **3.5hrs**
Frame **Integrated Aluminium Alloy 6061**
Rear Cassette (Chain) **Bike Single Speed (32T/16T)**
Brakes **TEKTRO 160 Hydraulic Disk Brakes**
Front Fork **Telescopic 100mm**
Tires **27.5" x 2.10" inches**
Weight **23Kg**
Waterproof **IP65**
Waranty **Motor & Battery: 24 months / Display & Controller: 12 months**
Price: **\$1.458 USD**





MZ003



MZ004

MANTIS eZERO Pro

Motor **E-MOBILITY Rear Hub Motor**
Nominal/Boost Power **350W**
Maximum speed **25 Km/h**
Display **Smart LCD colour**
Battery Type **Lithium-Ion LG 21700 5000mAh**
Battery Specs **36V 15Ah**
Range **70km (Full Power) - 110km (Eco)**
Charge Time **4.0hrs**
Frame **Integrated Aluminium Alloy 6061**
Rear Cassette (Chain) **Bike Single Speed (32T/16T)**
Brakes **TEKTRO 160 Hydraulic Disk Brakes**
Front Fork **Telescopic 100mm**
Tires **27.5" x 2.10" inches**
Weight **26Kg**
Waterproof **IP65**
Waranty **Motor & Battery: 24 months / Display & Controller: 12 months**
Price: **\$1.637 USD**

MANTIS eONE

MANTIS eONE

Motor **E-MOBILITY Rear Hub Motor**
Nominal/Boost Power **250W**
Maximum speed **25 Km/h**
Display **Smart LCD colour**
Battery Type **Lithium-Ion LG 21700 5000mAh**
Battery Specs **36V 10Ah**
Range **50km (Full Power) - 90km (Eco)**
Charge Time **3.5hrs**
Frame **Integrated Aluminium Alloy 6061**
Rear Cassette (Chain) **Bike Single Speed (32T/16T)**
Brakes **TEKTRO 160 Hydraulic Disk Brakes**
Front Fork **Telescopic 100mm**
Tires **27.5" x 2.10" inches**
Weight **23Kg**
Waterproof **IP65**
Waranty **Motor & Battery: 24 months / Display & Controller: 12 months**
Price: **\$1.430 USD**



MO001



MO002



MANTIS eONE Pro

Motor **E-MOBILITY Rear Hub Motor**
Nominal/Boost Power **350W**
Maximum speed **25 Km/h**
Display **Smart LCD colour**
Battery Type **Lithium-Ion LG 21700 5000mAh**
Battery Specs **36V 15Ah**
Range **70km (Full Power) - 110km (Eco)**
Charge Time **4.0hrs**
Frame **Integrated Aluminium Alloy 6061**
Rear Cassette (Chain) **Bike Single Speed (32T/16T)**
Brakes **TEKTRO 160 Hydraulic Disk Brakes**
Front Fork **Telescopic 100mm**
Tires **27.5" x 2.10" inches**
Weight **26Kg**
Waterproof **IP65**
Waranty **Motor & Battery: 24 months / Display & Controller: 12 months**
Price: **\$1.610 USD**



MO003



MO004

MANTIS eHYPER

Motor **E-MOBILITY Rear Hub Motor**
Nominal/Boost Power **350W**
Maximum speed **25 Km/h**
Display **Smart LCD colour**
Battery Type **Lithium-Ion LG 21700 5000mAh**
Battery Specs **36V 15Ah**
Range **70km (Full Power) - 110km (Eco)**
Charge Time **4.0hrs**
Frame **Integrated Aluminium Alloy 6061**
Rear Cassette (Chain) **Bike Single Speed (32T/16T)**
Brakes **TEKTRO 160 Hydraulic Disk Brakes**
Front Fork **ASIN Girder Fork**
Tires **27.5" x 2.10" inches**
Weight **25Kg**
Waterproof **IP65**
Waranty **Motor & Battery: 24 months / Display & Controller: 12 months**
Price: **\$1.791 USD**



MZ002



GEOMETRY

	Wheel diamete /size	M
A	Seat Tube C-T	500
B	Effective Top Tube Length	601
C	Head Tube Angle (°)	72
D	Seat Tube Angle (°)	73
E	Chain stay length	455
F	Bottom Bracket Offset	65
G	Head Tube Length	170
H	Fork Length	465
I	Wheel Base	1086
J	Frame Stack	658
K	Frame Reach	400

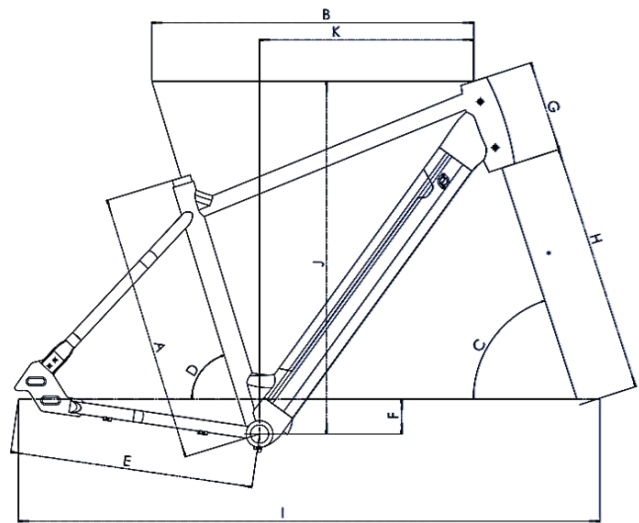

All the above are in mm unless otherwise indicated

Specifications are subject to change without notice. Imagery may not reflect most current product specifications. E-MOBILITY VIETNAM reserves the right to make improvements and/or design changes without any obligation to previously sold, assembled or fabricated equipment.

